

OWNER'S MANUAL

POOL LAB[®]

HYBRID

Commercial Water Quality Management

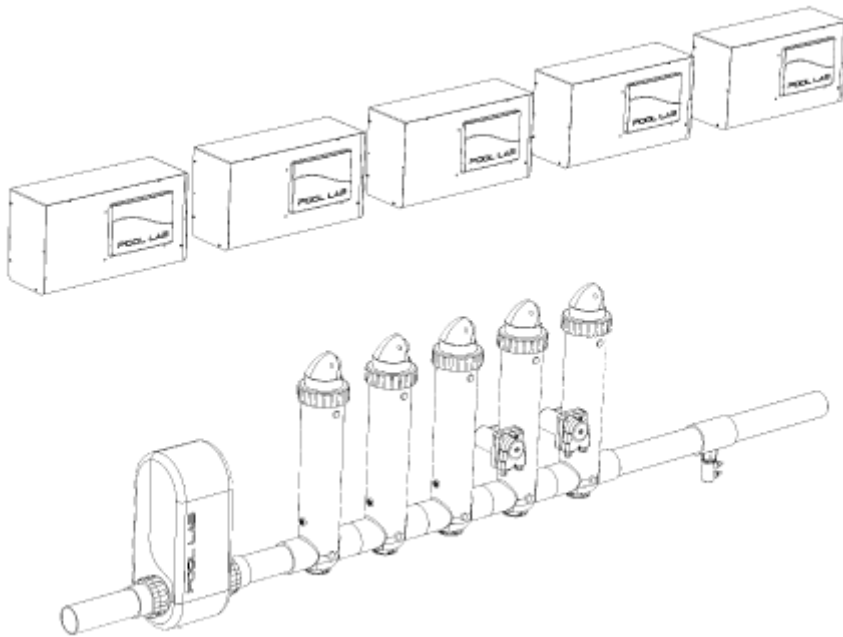

Patented Technology

Patent Technology
Numbers:

Australia No. 2004245133

Canada No. 2528374

Europe No. 04736187.8

New Zealand No. 544430

USA No. 7,658,842

IMPORTANT

Read this manual carefully before operating your Pool Lab Hybrid

PL COMM and PL LT Models
Ideal Salinity@ 25 °C = 3000ppm

KEEP THIS MANUAL IN A SAFE PLACE FOR FUTURE REFERENCE

Manufactured by Poolpower Australia Pty Ltd
Factory 1b, 39-45 Susan Street
ELTHAM, VICTORIA, AUSTRALIA 3095

email: service@poolpower.com.au

rev. 13

IMPORTANT SAFETY INSTRUCTIONS

When installing and using this electrical equipment, basic safety precautions must always be followed.

READ AND FOLLOW ALL INSTRUCTIONS

- **WARNING:** Disconnect all AC power during installation and or removal of the equipment.
- **WARNING:** Potential risk of fire, electric shock, or injury to persons if the installation and safety instructions listed in this manual, and on the equipment itself are not followed.
- **WARNING:** To reduce the risk of injury, do not permit children to use this equipment unless they are closely supervised at all times.
- **WARNING:** Always wear safety goggles and suitable gloves when handling pool chemicals, and follow usage directions carefully.
- **WARNING:** Use of a suitable respirator is recommended when handling Hydrochloric Acid (aka. Muriatic Acid).
- **DANGER:** DO NOT ADD WATER TO ACID. Always add acid to water
- **SAVE THESE INSTRUCTIONS FOR FUTURE REFERENCE**
- Heavy pool (or Spa) usage, and/or higher temperatures may require higher chlorine output to maintain proper free chlorine residuals.
- If additional chlorine is required due to heavy bather loads, use liquid chlorine (Sodium Hypochlorite) to maintain appropriate free chlorine residual.
- High salt or chlorine levels above recommended range may contribute to corrosion of pool or spa equipment.
- DO NOT add pool or spa chemicals directly to the skimmer.
- Check expiry dates of test kit consumables.
- Use only original Pool Lab replacement cells with identical model numbers.
- Follow all aspects of local and national Electrical Codes when installing Pool Lab equipment.

Health and Hypothermia Warnings

- People with a medical condition should consult a physician before entering the pool or spa water.
- Maximum safe spa water temperature is 40°C.
- Bathing in water at 40°C should not exceed 15 minutes.

Table of Contents

IMPORTANT SAFETY INSTRUCTIONS.....	2
Health and Hypothermia Warnings.....	2
GENERAL PRECAUTIONS.....	5
ELECTROLYTIC CELL PRECAUTIONS.....	5
INTRODUCTION.....	6
HYBRID SYSTEM OVERVIEW.....	7
CELL MAINTENANCE.....	8
TO REMOVE & INSPECT THE ELECTRODE.....	8
CLEANING THE ELECTRODE – CALCIUM SCALE.....	9
INSTALLING THE ELECTRODE.....	9
CONTROL PANEL OVERVIEW.....	10
SETTING THE TIME AND DATE.....	11
SETTING ON / OFF TIMERS.....	11
SETTING THE POOL AND SPA VOLUMES.....	12
SPECIAL FEATURES.....	13
USER AUTHORITY LEVEL.....	13
PUMP PROTECTION MONITOR.....	13
RECOVERY MODE.....	14
PLUMBING FLUSH.....	14
Wi-Fi®.....	15
Getting Started.....	15
How to Reset the Wi-Fi Module.....	16
PL CHLORINATOR MODELS.....	17
PL Classic / PL ECO.....	17
PL Plus.....	17
PL MAX.....	17
PL HYBRID (PL COMM & PL LT).....	17
RATED CHLORINE OUTPUT.....	17
ADD-ON MODULES.....	18
ASP.....	18
EXP.....	18
HYDROGEN GAS SAFETY.....	19
DIAGNOSTIC MESSAGES.....	20
CHECK SALT.....	20
CHECK SALT CELL OFF.....	20
HIGH SALT.....	20
HIGH SALT CELL OFF.....	20
PUMP PROTECTION ACTIVE.....	21
LOW FLOW.....	21
DEFAULTS USED.....	21
MEMORY FAULT.....	21
CHLORINE PRODUCTON AND CONTROL.....	22
FREE CHLORINE LEVEL.....	22
COMBINED CHLORINE - CHLORAMINES.....	22
CONTINUAL BREAKPOINT CHLORINATION.....	23
WATER BALANCE.....	24
pH.....	24
TOTAL ALKALINITY.....	24
CALCIUM HARDNESS.....	24
SALT LEVEL.....	24
CHLORINE STABILIZER – CYANURIC ACID.....	25
High Calcium (Hard) water sources – the Langlier Saturation Index.....	26
WATER CIRCULATION.....	27

INSTALLATION.....	28
PLUMBING.....	28
Cell Installation.....	28
Positioning the Cells.....	28
Multiple Cell Installations.....	28
Plumbing Examples.....	29
Cell Layouts to Avoid.....	31
Chemical Injection.....	32
POWER SUPPLY AND CONTROLLER.....	33
WIRING DATA CABLES AND ACCESSORIES.....	34
THIRD PARTY EQUIPMENT CONTROLLERS.....	35
POWER RATINGS	36
PL COMM.....	36
PL LT.....	36
Power Consumption	36
Pool Lab Add-on modules and accessories.....	37
ASP.....	37
EXP.....	37
SPA FLOW SWITCH (Domestic Plus and MAX models only).....	37
SALT.....	38
INITIAL SALT DOSING.....	38
SALT ADDITION TABLES.....	39
TROUBLESHOOTING.....	40
WARRANTY INFORMATION	43

GENERAL PRECAUTIONS

- **Do not use bromine** based products in the pool. Use of bromine will void the warranty on your chlorine cell.
- **Avoid the use of persulfate** based products as this can adversely affect free chlorine test results. Pool Lab recommends to shock dose with liquid chlorine.
- It is the pool owner's responsibility to ensure water is regularly tested and balanced. Your local pool professional can advise you on appropriate testing frequency and balance criteria in your area.
- Where calcium hardness of the pool / spa water exceeds 200ppm, the water must be balanced as per the Langlier Index to ensure water is not scale forming. Consult you local pool professional for advice.
- Do not assume the chlorinator is faulty if a chlorine test reveals a low free chlorine level. There are many factors that relate to chlorine demand in the water. Refer to the troubleshooting guide in this manual for more information
- Regular manual 'super chlorination' or 'shock dosing' may be required in pools where chlorine demand or bather load is high.
- Test salt level before calculating your salt addition requirements, even on a new installation – especially where liquid chlorine had been used previously.
- Free chlorine levels above 4.0ppm may void manufacturer warranties on your equipment.
- Unnecessarily high salt levels may contribute to corrosion of pool and spa equipment.
- The use of Cyanuric Acid (Stabilizer) is generally not recommended in commercial applications with high bather loads.

ELECTROLYTIC CELL PRECAUTIONS

- **It is a condition of the warranty that the pool owner ensure that the cell is inspected and maintained in accordance with the directions in this manual.**
- The chlorine cell is generally self cleaning, but certain water conditions can inhibit the effectiveness of this function. Therefore the cell should be visually inspected on a regular basis to ensure it is not fouled with debris or accumulating calcium. Refer to instructions on cleaning the cell in this manual if required.
- If calcium scale is allowed to build up on the electrode plates to the point where the calcium bridges the gap between the plates, this can permanently damage the electrode and will void the electrode warranty.
- If you have water conditions that cause calcium to build up in the chlorine cell, then the cell **MUST** be cleaned on a regular basis as per the instructions in this manual. *As a general rule, if the cell requires more than 15 minutes to clean, then it must be cleaned more regularly.*
- **It is the pool owner's responsibility to ensure all materials in contact with the pool or spa water are compatible with and intended for use with an electrolytic salt chlorinator.**

INTRODUCTION

Congratulations, you have wisely purchased the most technologically advanced water quality management system in the world. The benefits of doing so will be evident for many years to come. Pool Lab's research and development team is committed to producing the finest salt chlorination and water quality management systems, and being recognized world wide as the leaders in these technologies.

Your Pool Lab chlorinator will eliminate the need for daily manual chlorine dosing and the risks associated with these practices. It is automatic, clean, safe and economical and for these reasons salt chlorination as a method for treating pool water is increasing world-wide.

All Pool Lab Hybrid systems include a Pool Lab ASP (Auto Sampling Photometer) which utilizes proven photometric technology and a patented analysis technique to automate control of the pH and free chlorine levels in your pool or spa. It takes the guesswork out of balancing and treating your water, and through automation significantly reduces labour and the requirement to regularly handle dangerous chemicals.

Mild salt water is gentle on eyes and skin and is said to benefit asthma sufferers and those people who find conventional chlorinated pools irritating. The salinity of seawater is approx. 35,000ppm or 3.5%, while Pool Lab chlorinators require only 3,000ppm or 0.3%. The human body has a salinity of approx. 4500ppm and fresh water is zero. It is the similarity between the salinity of the human body and that of a salt pool that make for a silky luxurious swimming experience.

The chlorinator comprises two basic components, the power supply and cell. It is within the cell that the electrolytic reactions occur. Chloride ions in the water are converted into chlorine gas, this dissolves immediately into the water to ultimately form sodium hypochlorite (liquid chlorine). The chlorine oxidizes bacteria, algae and other harmful matter in the pool water and through this process reverts back into available chloride ions.

The major by-product of the reaction in the cell is the liberation of Hydrogen gas at the cathode. This explains the small bubbles often seen passing out of the pool returns. Pool Lab's patented vertical cell is the worlds safest and ensures the excess hydrogen gas can not accumulate to dangerous levels.

No salt is lost through the electrolytic process. The necessity to top up the salt level is only due to loss of salt water from backwashing or splashing out etc. Water loss due to evaporation does not cause any loss of salt. All Pool Lab models contain digital time clocks with two programmable ON/OFF periods available for fully automatic operation of your pump & chlorinator.

All models have a built in back up power system that will keep the timer clock running for up to 7 days. This is particularly useful where the mains power is interrupted.

Pool Lab PL Series does not contain batteries.

HYBRID SYSTEM OVERVIEW

The Pool Lab Hybrid System is a scalable water quality management system specifically designed to cater for small to medium sized commercial pools and spas, as well as larger high demand domestic pools.

The system consists of the following components:

- PL Commander (45 gram per hour salt chlorinator and master controller)
- (optional) PL Lieutenant (up to 4 x) (45 gram per hour salt chlorinators)
- ASP (Auto sampling photometer)
- Acid Feed Pump
- Liquid Chlorine Feed Pump

All Pool Lab Hybrid Systems include 1 x Pool Lab Commander acting as the master controller to which you can connect up to 4 x Pool Lab Lieutenants depending on the chlorine output required. (each additional Lieutenant adds 45 grams per hour chlorine output)

The Pool Lab Hybrid System is therefore available in 5 configurations:

Hybrid 45 - 1 x PL Commander (45 grams per hour)

Hybrid 90 – 1 x PL Commander + 1 x PL Lieutenant (90 grams per hour)

Hybrid 135 – 1 x PL Commander + 2 x PL Lieutenant (135 grams per hour)

Hybrid 180 – 1 x PL Commander + 3 x PL Lieutenant (180 grams per hour)

Hybrid 225 – 1 x PL Commander + 4 x PL Lieutenant (225 grams per hour)

All Pool Lab Hybrid systems utilize the highly successful Pool Lab ASP (Auto Sampling Photometer) to monitor chlorine and pH levels in the water, allowing the system to automatically adjust chlorine output as required to maintain the free chlorine level and dose Hydrochloric acid as required to maintain your pH level.

Pool Lab Hybrid systems feature a liquid chlorine backup for occasions when chlorine demand exceeds the salt chlorinators output capability. The liquid chlorine feed pump is capable of delivering up to an additional 450 grams of chlorine per hour (assuming 12.5% liquid chlorine, and a feed rate of 60ml per minute) as required to cope with spikes in chlorine demand and recovery after heavy bather loads.

Each Commander and Lieutenant module has the option of controlling a single filtration pump (single phase up to 8.4 Amps – or approx. 2 HP) and all filtration pump outputs are controlled from the Commander module. Alternatively pumps can be controlled externally, or via a third party controller.

CELL MAINTENANCE

Where calcium levels are below 200ppm, the mineral content is low and the water is correctly balanced, little or no maintenance to the cell is normally required. The automatic reversing of the electrode polarity will be sufficient to dissolve the calcium scale formed.

Periodic inspections must however be made to ensure scale and or debris is not forming or building up on the electrodes within the cell. If a calcium scale has formed it must be removed by cleaning in an acid solution.

Where calcium levels are higher than 200ppm and or mineral content is high, regular inspections of the cell must be performed. If calcium scale is present, the cell must be cleaned in an acid solution. The higher the water temperature, the greater the capacity for the water to deposit scale on the cell. Each pool will vary with regard to the frequency of cell maintenance. Factors which increase the cell cleaning frequency are:

- Calcium Hardness above 200ppm
- High Water Temperatures
- Low water velocity
- Poor Water Balance
- Excessive salt level
- Electrode breakdown – ensure a qualified technician evaluates the cell

TO REMOVE & INSPECT THE ELECTRODE

- Switch off power to the chlorinator and pump(s).
- Close all relevant valves – especially where the cell is located lower than the pool water level, or where the pump(s) are significantly above the water level.
- Unplug the cell cable from the cell, and place cable end in a dry location.
- Loosen the large cell nut, and remove it from the cell.
- Carefully remove the electrode from the cell housing. Where the cell is located above the pool water level, and the cell is not completely isolated by valves, beware that there may be a vacuum in the cell housing. This can sometimes make the electrode difficult to remove. Take care not to lose the o-ring.
Depending on your system setup, the vacuum can sometimes be relieved by briefly pushing down on the multi-port valve handle on a sand filter, or by opening a relief or drain valve momentarily.
- Visually inspect for debris accumulated at the bottom of, or between the electrode plates. Most debris can usually be cleared by simply dunking the electrode up and down rapidly in water. Excessive debris could indicate a filtration problem.
 - * **DO NOT USE A METAL TOOL TO REMOVE DEBRIS AS THIS WILL DAMAGE THE ELECTRODE COATING!!**
 - * **DO NOT ATTEMPT TO MANUALLY REMOVE ANY CALCIUM SCALE**
- Visually inspect between the electrode plates for calcium build up. This appears as a hard white material that coats the surface of the plates and can also bridge the gap between the plates. Electrode plates should be smooth and matte black.

CLEANING THE ELECTRODE – CALCIUM SCALE

You will need hydrochloric acid (33%), and a plastic container or bucket deep enough to stand the electrode vertically in with the electrode plates fully submerged. The container or bucket should be preferably not too broad, as this will require a larger amount of acid. A standard 10 Litre bucket is usually acceptable.

You will also need safety goggles and protective gloves.

- Remove any loose debris from the electrode by dunking it up and down rapidly in water.
- In your container or bucket mix approximately 1 part hydrochloric acid to 5 parts water. Make the solution slightly too shallow at first, then top up later with water to just cover the electrode plates.

Note: Less acid can be used (down to 1:10 ratio) if the calcium build up is not too excessive, but the cleaning process will take longer.

ALWAYS PUT WATER IN THE CONTAINER FIRST, THEN ADD ACID.

- Carefully place and stand the electrode in the container, **taking care NOT to submerge the top part** where the electrical connector is. Top up the container with fresh water if required until the electrode plates are just covered by the solution.
Note: ACID REACTING WITH THE CALCIUM SHOULD PRODUCE BUBBLES
- Leave the electrode in the solution until the bubbles stop. The reaction will usually be fast initially, then slow down.
- Once you are satisfied the reaction has stopped, carefully remove the electrode from the solution, and rinse with fresh water.
Note: If calcium scale was excessive you may need to repeat this process with a fresh acid solution.
- Visually inspect the cell to ensure you are satisfied it is clean. If some scale-like build up remains and it appears that acid is not removing it, then it may not be calcium scale. You can try rinsing the cell with hot tap water (not boiling water) which can sometimes help.

INSTALLING THE ELECTRODE

- Visually inspect the condition of the o-ring, and replace if necessary.
- Apply a small amount of silicone grease to the o-ring if required.
- Fit the o-ring to the cell head, ensuring it is on the bottom side of the cell head flange (same side as the electrode plate bundle).
- Fit the electrode into the cell housing, and orient it so that the cell cable can plug into the cell easily and comfortably.
- Fit the cell nut, and tighten by hand only.
- Connect the cell cable to the cell.
- Open any valves that were closed prior to the electrode being removed.
- Re-connect power to the chlorinator and pump(s).
- Run the system – and check for any leaks.

CONTROL PANEL OVERVIEW

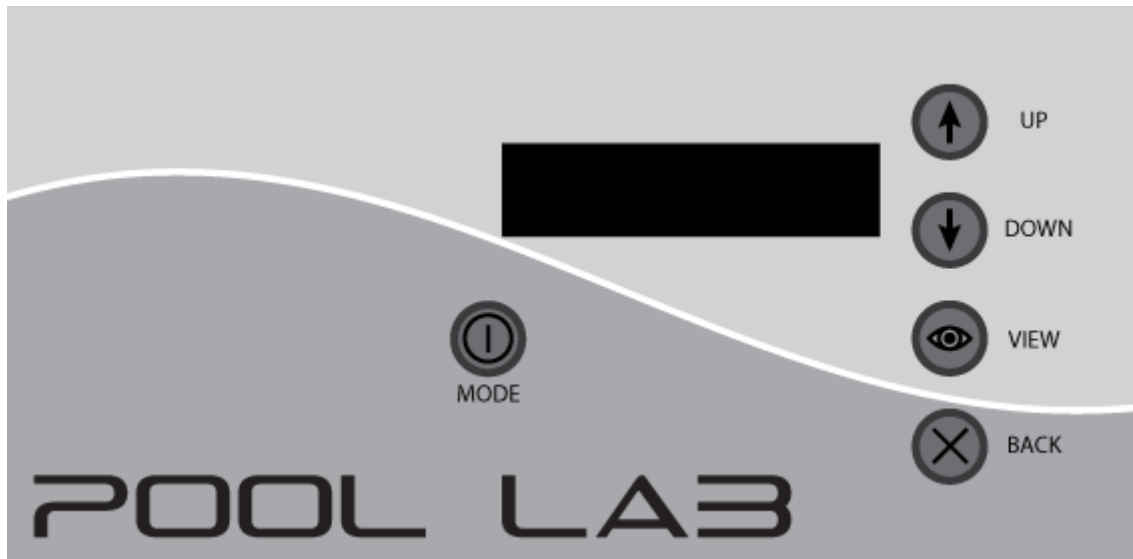

All Pool Lab Hybrid models are controlled from the PL-COMM (Commander)
PL-LT (Lieutenant) displays are for diagnostic messages only.

LCD DISPLAY

- The display has three top level views, and a menu system:
 - HOME – Displays running mode and chlorinator output.
 - TIME/DATE – Displays current time and date
 - TIMER – Displays filtration ON / OFF times
 - MAIN MENU – Access settings and configuration items

UP / DOWN BUTTONS

- Adjust the chlorine output level (view “HOME” with no ASP)
- Adjust the time / date (view “TIME/DATE”)
- Adjust the ON / OFF times (view “TIMER”)
- Navigate menu system (menu system list views)
- Adjust values (menu system field editing)

VIEW BUTTON

- Switch between LCD display top level views
- Moves to the next adjustable field, or set adjusted field
- Hold for 5 seconds to enter the MAIN MENU (view “HOME” only)
- Select a menu item, or edit a field (menu system views)

BACK BUTTON

- Return to previous view, or return to view “HOME”
- Exit adjustment mode
- Display detailed cell output data (view “HOME”)

MODE BUTTON

- Toggle ON / OFF / AUTO running mode.
- Returns to HOME VIEW (from any top level view)

SETTING THE TIME AND DATE

Time is displayed in 24 hour format. 00:00 is midnight, 12:00 is midday.

Date is displayed in day / month / year format.

Setting the correct date will allow the system to automatically adjust for daylight savings time.

The clock will continue to run for several days without power. If power is disconnected for an extended period of time, the clock may reset.

- Press the VIEW button once from the HOME VIEW to display the TIME / DATE VIEW.
- Current time and date settings are displayed.
- Press either the UP or DOWN button once to enter adjustment mode.
- The HOUR digits will be flashing to indicate adjustment mode.
- Use the UP and DOWN buttons to select the correct HOUR value
- Press VIEW to switch to the MINUTES field.
- Use the UP and DOWN buttons to select the correct MINUTES value
- Continue this process for YEAR, MONTH, and DAY fields.
- Press VIEW to save the settings.

SETTING ON / OFF TIMERS

Two separate ON / OFF time periods for the filtration pump are available. You can use either one, both or none of these depending on your requirements.

Time periods can be set to traverse midnight.

Time periods can overlap, in which case they will be treated as one time period.

Either or both of the timers can be disabled by setting both ON and OFF times the same.

A disabled timer will show ON and OFF times as dashes (--:--)

Timers are labeled #1, and #2.

The first column shows the ON time.

The second column shows the OFF time.

Time period settings should be retained even after extensive periods without power.

- Press the VIEW button twice from the HOME VIEW to display the TIMERS VIEW.
- Current ON / OFF times are displayed.
- Press either the UP or DOWN button once to enter adjustment mode.
- The HOUR digits of ON time #1 will be flashing to indicate adjustment mode.
- Use the VIEW button to cycle to the field you need to adjust.
- Use the UP and DOWN buttons to select the correct value.
- When finished, use the VIEW button to cycle past the last adjustable field to save the settings.

SETTING THE POOL AND SPA VOLUMES

Pool Lab Hybrid systems are designed to be used on a single body of water only, ie. A pool or a spa.

NOTE: Pool Lab Hybrid is generally not recommended for Pool and Spa combination systems unless the two bodies of water can be completely separated from each other – with separate pumps and filtration systems, and separate Pool Lab Hybrid systems.

Before commissioning a Pool Lab Hybrid system it is important to set the water body volume and type (ie. Is it a pool or a spa).

- Press and hold the VIEW button from the HOME VIEW until the MAIN MENU appears.
- Use the UP and DOWN buttons to navigate to SYSTEM CONFIG and then press VIEW
- You may need to set the AUTHORITY to INSTALLER **(this will be already set by default on a brand new unit until midnight)**
Navigate to AUTHORITY and press VIEW.
Press the VIEW button once again to edit the value (flashing)
Use the UP/DOWN buttons to change the value to “INST” and press VIEW
Press BACK once to return to the SYSTEM CONFIG MENU
- Use the UP and DOWN buttons to navigate to POOL/SPA VOLS and press VIEW
- Navigate to the appropriate POOL or SPA volume and press VIEW to edit the value.
- Use the UP and DOWN buttons to adjust the value and press VIEW to save the new value, or BACK to cancel editing.

You will also need to set the POOL / SPA type (located below SPA VOLUME)

This value is set to POOL by default. The system will use the POOL VOLUME only in default configuration (SPA VOLUME is ignored).

If you are setting up a Pool Lab Hybrid system on a spa, then this value will need to be set to SPA, and the SPA VOLUME set appropriately.

Pool Mode – has stricter chemical delivery limits to avoid overdosing a large volume of water, and large changes in pH value will lock out acid delivery for 24 hours.
When in AUTO or ON mode, the ASP water tests will always be scheduled based on the TESTS PER DAY and TEST PERIOD setting in the SETTINGS menu.

Spa Mode – allows for greater acid delivery per litre of water, and will not lock out acid feed in case of a sudden increase in pH.
When in AUTO mode, the ASP water tests will always be scheduled based on the TESTS PER DAY and TEST PERIOD setting in the SETTINGS menu.
When in ON mode, the ASP water tests will always be scheduled every half hour.
(This can be adjusted if required - see TECHNICAL MANUAL)

SPECIAL FEATURES

USER AUTHORITY LEVEL

To prevent accidental changes to critical settings, the Pool Lab PL Series incorporates a user authority level. By default the authority level is set to USER. Before any critical settings can be edited, the user authority level must be raised to INSTALLER. There is also a LIMITED level which prevents adjustment of all settings, and there are also TECHNICIAN and FACTORY levels which require a PIN.

To enable editing of system settings, you must first raise the AUTHORITY level to INSTALLER.

- From the HOME VIEW, press and hold the VIEW button for at least 5 seconds.
- This will show the MAIN MENU.
- Navigate to SYSTEM CONFIG, and press VIEW
- Navigate to AUTHORITY, and press VIEW
- Press VIEW again to edit the AUTHORITY setting.
- Press the UP / DOWN keys to change the setting to INST (ie. INSTALLER)
- Press the VIEW button to save the setting.
- Press BACK button twice to return to MAIN MENU

PUMP PROTECTION MONITOR

This feature monitors the amount of time the system has been in a low flow situation and will turn off the filtration pump after a predetermined amount of time to protect the pump from damage. For systems with a sand filter we recommend a minimum of 5 minutes so that the feature does not interrupt backwashing.

To set the PUMP PROTECTION TIME period:

- Set the AUTHORITY level to INSTALLER as described above.
- From the MAIN MENU navigate to SETTINGS, and press VIEW.
- Navigate to the PUMP PROTECTION field and press VIEW to edit.
- Use the UP and DOWN buttons to adjust the time in MINUTES.
- Press the view button to save the setting.
- Press the BACK button to exit.

The pump protection feature will be enabled when the PUMP PROTECTION TIME is set to any number greater than ZERO.

To disable PUMP PROTECTION MONITOR, set the PUMP PROTECTION TIME to ZERO.

Disable pump protection when filtration pump(s) are controlled externally and not connected to the Pool Lab pump sockets.

RECOVERY MODE

Recovery mode will run the filtration system and chlorinator for the amount of time set in SETTINGS - RECOVERY (default setting is 24 hours), then revert back to AUTO filtration mode. This may be useful when additional filtration and/or chlorination is required after periods of heavy use, or when cleaning / preparing a pool for the swimming season.

To enter RECOVERY mode:

- From the HOME view, press and hold the UP button for at least 5 seconds.
- The display will cycle to show the recovery time remaining.

To exit RECOVERY mode:

- Press the MODE button once to put the system into OFF mode.
- This will cancel the recovery timer.
- Set the mode as required to resume normal operation.

To set the RECOVERY MODE timer period:

- From the MAIN MENU navigate to SETTINGS, and press VIEW.
- Navigate to the RECOVERY field and press VIEW to edit.
- Use the UP and DOWN buttons to adjust the time in HOURS (1 – 48 hours).
- Press the view button to save the setting.
- Press the BACK button to exit.

PLUMBING FLUSH

This feature is automatic, no programming or adjustments are necessary. When in AUTO mode, the cell power will automatically switch off 30 seconds before the pump to ensure cell housing and plumbing is flushed of concentrated chlorine. This unique feature prevents high chlorine levels in the pipework diffusing through and corroding heater tube bundles and the possibility of damaging other sensitive equipment up-stream of the cell.

Wi-Fi®

Pool Lab Hybrid chlorinators are equipped with a Wi-Fi module that will allow remote control and monitoring of your system via the mobile apps available for iOS and Android.

A small Wi-Fi antenna is supplied in the box along with your Pool Lab Commander. After the chlorinator is installed, attach the antenna to the connector on the bottom of your chlorinator. Tighten nut with fingers only – do not over tighten.

When you first power up a new chlorinator the Wi-Fi module will be in setup mode (aka. Hotspot mode) and will appear as a wireless access point with SSID “poolLab”. It will remain in this mode for up to 2 hours before timing out. If you do not complete setup within two hours, you will need to reset the Wi-Fi module (next page) or cycle power to the chlorinator to restart setup mode.

Getting Started

Download the app on your mobile device from the app store. Search for “Pool Lab”, by Poolpower Australia Pty Ltd.

Open the app and sign up for a free account. This will require an account name, email address and password.

Sign into your account, and the setup wizard will begin automatically.

The first step is to let the app know which Wi-Fi network you wish the Pool Lab Chlorinator to connect to – for example, your home Wi-Fi. You will also need to enter the password for this connection as this information will need to be sent to the Pool Lab Chlorinator after the next step.

The second step is to search for your Pool Lab chlorinators Wi-Fi module, which should be in setup mode (aka. Hotspot mode). It should appear as a network with the name/SSID “poolLab”. Depending on your operating system and security settings it may ask for a password, which is “123456789”.

Once you have completed this step, the connection details for your selected Wi-Fi network will be sent to the Pool Lab Chlorinator via a secure peer-to-peer connection. The Pool Lab chlorinator will then attempt to connect to the network you selected, and if successful the Setup Wizard will finish automatically.

If the setup wizard fails for any reason you may need to restart it and try again.

If the “poolLab” network does not appear, you may need to cycle power to your chlorinator, or reset your Wi-Fi module (see below). Also, ensure the Wi-Fi antenna supplied with the unit has been attached on the bottom of your chlorinator.

How to Reset the Wi-Fi Module

Resetting the Wi-Fi module will clear any saved Wi-Fi connection information and set the Wi-Fi module into “Hot Spot” mode ready for running the Setup Wizard in the Pool Lab mobile apps.

The Wi-Fi module will remain in “Hot Spot” mode for up to 2 hours, or until the Setup Wizard is complete. During this time the Wi-Fi module will appear as a Wi-Fi access point with the SSID “poolLab”, and password “123456789”.

If you do not complete the Setup Wizard within 2 hours window, the Wi-Fi module will turn OFF. To re-enter “Hot Spot” mode you can either reset the Wi-Fi module again, or simply cycle power OFF and back ON to the Pool Lab Chlorinator.

Once the Setup Wizard has been completed the Wi-Fi connection information will be saved to the memory of the Wi-Fi module, allowing it to connect automatically to your selected Wi-Fi network as required. The saved information will persist through power outages and Wi-Fi network interruptions, etc.

If your Wi-Fi network password or SSID changes, then you will need to reset the Wi-Fi module and complete the Setup Wizard again.

- From the HOME view, press and hold the VIEW button until the MAIN MENU appears.
- Navigate to SYSTEM CONFIG and press the VIEW button.
- Navigate to AUTHORITY and press the VIEW button.
- Press the VIEW button once more to edit the AUTHORITY level (flashing), and press UP once to set this to “INST”. Press VIEW again to save the value.
- Press BACK once to return to the SYSTEM CONFIG menu.
- Navigate down to RESET WIFI and press the VIEW button.
(Note: this option will only appear if AUTHORITY is set to INST or higher)
- Press VIEW to reset the Wi-Fi module, or press BACK to cancel.

PL CHLORINATOR MODELS

PL Classic / PL ECO

Stand-alone salt chlorinators that includes all the features you need for a basic system. Suitable for use on swimming pools that are a single body of water. These models are not recommended for spas or pool and spa combination systems, and do not provide connectivity with the Pool Lab add-on modules. See Plus and MAX models below.

PL Plus

An advanced salt chlorinator suitable for use on pools, and pool and spa combination systems¹. Compatible with the Pool Lab ASP that enables automatic pH and free chlorine level control, and the Pool Lab EXP that enables additional features such as integrated solar and gas heating controls as well as control of third party equipment such as lighting, pumps and flow control valves.

Plus (and MAX) models are also suitable for spa only² systems when used in conjunction with the Pool Lab ASP.

PL MAX

The flagship of the Pool Lab Salt Chlorinator range. This model includes all the features of the Plus model and also includes multi-speed pump control, and is Wi-Fi® enabled. With apps available for iOS and Android this allows for remote monitoring and control of your system from anywhere in your home, or anywhere in the world³! Smart speaker integration is also possible with skills available for most popular devices.

PL HYBRID (PL COMM & PL LT)

The commercial version of the Pool Lab Salt Chlorinator is a system that can be scaled to suit your requirements. The PL COMM is the “Commander” and you can add up to four additional PL LT “Lieutenant” chlorinators for a total chlorine output of between 45 – 225 grams per hour (chlorine gas). The PL COMM is specifically designed to operate in conjunction with the Pool Lab ASP on a single body of water and also features the ability to feed liquid chlorine to meet chlorine demand even under extreme conditions. This model includes compatibility with the Pool Lab add-on modules, multi-speed pump control, and is Wi-Fi® enabled with apps available for iOS and Android.

Note: Not suitable Pool & Spa combinations, as separate filtration systems are required.

RATED CHLORINE OUTPUT

Chlorine output is measured in units of grams of chlorine gas per hour (gm/hr). PL Classic, Plus and MAX models are available in 25gm/hr, 35gm/hr and 45gm/hr variations. PL Hybrid models are all rated at 45gm/hr, and one Commander can operate by itself or optionally control up to 4 x Lieutenants for total rated output options of 45gm/hr, 90gm/hr, 135gm/hr, 180gm/hr and 225gm/hr.

1 Pool and Spa combination systems require a spa flow switch, sold separately.

2 Spa only systems require the ASP add-on module, and do not require a spa flow switch.

3 Requires internet connection on the network that the Pool Lab MAX is connected to and internet connection on the device running the Pool Lab app.

ADD-ON MODULES

ASP

The Pool Lab ASP or Auto Sampling Photometer is the World's most reliable and accurate water management system. The ASP will periodically test your water for Free Chlorine and pH levels and adjust the chlorinator output and feed acid as required. Developed and Patented by Poolpower Australia Pty Ltd, the ASP does not suffer from the limitations of ORP probe based systems and the accuracy is not affected by stabiliser levels, hydrogen gas or changes in pH. The ASP does not require cleaning or calibration and is suitable for use on both pools and spas, as well as combination pool and spa systems. Reagent sets require replacement after approximately 700 tests, or 6 – 8 months at 3 tests per day.

EXP

The Pool Lab EXP or Expansion Module allows you to control of all of your pool and spa equipment from your Pool Lab Commander or from the convenience of your mobile device or smart speaker. The system features:

- Fully integrated solar heating control. Compatible with isolated solar systems, multi-pump split solar systems, retro-fit or boost pump systems, as well as valve controlled solar on single pump systems.
- Fully integrated gas heating control, which is also compatible with heat pumps that have the option for external control.
- Control of up to 4 flow control valve actuators for pool and spa combination systems, solar systems, water features, in-floor cleaning systems, etc.
- Control up to 9 x 240V outlet sockets for equipment such as lighting, pumps, cleaners, or any other plug in equipment.

The EXP is available in two models:

EXP5 – features 5 x 10 Amp, 240V standard outlet sockets with a maximum total load of 10 Amps. This model plugs into a standard 10 Amp power socket so in most cases will not require an electrician to install, and is suitable for many simple domestic systems.

EXP9 – features 9 x 10 Amp, 240V standard outlet sockets with a maximum total load of 20 Amps. The power lead on this model is fitted with an Industrial 3 (round) pin 20 Amp plug, so installation may require an electrician to provide a suitable switched power outlet socket.

In cases where control of higher power or 3 phase equipment is required, an electrician may be required to install contactors to control this equipment.

HYDROGEN GAS SAFETY

You may take comfort from the fact that the Pool Lab Cell has worldwide patents on its design relating to safety.

Pool Lab has the worlds safest Cell

Your Pool Lab Chlorinator must be installed in accordance with the installation instructions listed in this manual.

The cell, apart from producing chlorine, produces a byproduct gas Hydrogen. Hydrogen is not readily dissolved in the water and under normal filtration conditions passes through and out of the pool returns, harmlessly dissipating into the atmosphere.

If however the water flow is restricted (blocked skimmer box or filter, incorrectly closed valve, etc) then these gases can collect in the system. A potentially explosive mixture could result under certain conditions.

The Pool Lab chlorinator has eliminated this potential hazard with in-build electronic and physical safety features.

Primarily it is important that whenever chlorine is produced that we have water flow to transport the byproduct hydrogen gas through the return pipes, to the eyeball returns and to atmosphere. We have three mechanisms that ensure this occurs:

- If the water flow stops, or slows to the point where hydrogen gas is not being expelled from the cell housing, then the sensor at the top of the chlorinator cell detects this, and switches power off to the cell. The unit remains on standby until correct water flow is re-established. A message Low Flow – OFF is displayed on the LCD.
- It is an installation requirement that the filter pump is electrically interconnected with the chlorinator and operating from the one time clock. This ensures simultaneous operation of the filtration pump and the chlorine cell.
- The most important hydrogen gas containment feature is the Pool Lab's physical cell design. It's unique patented vertical design ensures that even in the unlikely event that the electronic flow protection features fail, the gas will be contained to a volume of less than 2lts within the cell housing. In this situation, no more gas can possibly be produced, since the electrode plates are no longer in contact with the water.

DIAGNOSTIC MESSAGES

Diagnostic messages will be displayed on the bottom line of the LCD when in HOME VIEW. The messages and their meanings are explained below, with some basic tips to rectify the issue if necessary. If the problem persists, consult the troubleshooting guide for more information.

CHECK SALT

The system has detected unusually low conductivity in the cell, possibly due to a low salt level, and is running inefficiently. The system will continue to run as normal, but may not be able to produce chlorine to its full potential. This can also be caused by very cold water, in which case the message can generally be ignored.

- Check the salt level, and add salt if required
- Inspect the cell for debris or calcium scale

CHECK SALT CELL OFF

The system has detected critically low conductivity in the cell, possible due to a very low salt level. Power to the cell has been turned off to prevent damage. The filtration system will run as normal, but no chlorine will be produced. Once every five minutes, the system will re-check and resume normally if the condition is rectified.

- Check the salt level, and add salt if required
- Inspect the cell for debris or calcium scale

HIGH SALT

The system has detected unusually high conductivity in the cell, possibly due to a high salt level. Usually no user action is required, this is just a warning not to add any more salt. Chlorine can still be produced efficiently, but it is nearing the threshold where it could trigger HIGH SALT CELL OFF. This message is more likely to appear at higher water temperatures.

- Check the salt level, and top up the pool with fresh water if possible
- DO NOT ADD SALT

HIGH SALT CELL OFF

The system has detected critically high conductivity in the cell, possibly due to a very high salt level, or a combination of high salt and high water temperatures. Power to the cell has been turned off to prevent damage. The filtration system will continue to run as normal, but no chlorine will be produced. Once every five minutes, the system will re-check and resume normally if the condition is rectified.

- Check the salt level, and top up the pool with fresh water if possible
- DO NOT ADD SALT
- If the salt level is significantly too high, it may be necessary to drain some water and top up with fresh water.

PUMP PROTECTION ACTIVE

The system has detected a low flow condition for longer than the time specified in the PUMP PROTECTION TIME setting. The pump has been turned off, and will not restart until the filtration mode is changed manually.

- Press the MODE button to toggle the filtration mode back to AUTO or ON.
- Refer to LOW FLOW recommendations below.

LOW FLOW

The system has detected a low flow condition, and will not be producing any chlorine.

- Check visually for water flowing through the cell. An air or gas pocket at the top of the cell housing indicates that there is not enough flow.
- Inspect the cell for debris or calcium scale
- Check skimmer baskets and pump baskets, empty them if required.
- Backwash the filter if necessary - (sand filters only)
- Clean the filter cartridge(s) if necessary – (cartridge filters only)
- Check all valve positions are correct.

DEFAULTS USED

The system could not read valid user settings from EEPROM memory, therefore factory default settings have been loaded. It is normal for this to occur on a new unit at initial power up, or after a memory reset. Otherwise it could indicate that the memory was somehow corrupted, for example if power was cut whilst a changed setting was being saved to memory. Although it would be extremely rare for this to occur.

MEMORY FAULT

The system could not successfully write to and read back from the internal memory. This generally indicates a major fault with the PCB, and it is likely that user settings, timers, running modes, etc. may not be able to be saved. Operation of the unit could be unpredictable. Try to cycle power to the unit off, and back on again. If the problem persists – return the unit for service.

CHLORINE PRODUCTON AND CONTROL

FREE CHLORINE LEVEL

A average free chlorine residual of 1.0ppm to 3.0ppm must be maintained in the pool / spa water at all times.

The ability of the chlorine generator to maintain this level will alter with respect to the chlorine demand imposed by bather load and environmental factors.

The chlorine output level [%] is displayed on the LCD and is normally automatically controlled by the ASP when installed. If an ASP is not used, then the chlorine output may be altered using the UP and DOWN buttons. This allows you to increase or decrease the chlorine production without alteration of the operation time.

Testing for chlorine levels is very important and should be performed on a daily basis. The sample of water to be tested should be taken at arms depth away from the pool returns. This avoids highly chlorinated water, which has traveled directly from the chlorinator cell and ensures the reading will be a true representation of the pools residual level.

When a test reveals low chlorine (or zero) chlorine, always treat manually with liquid chlorine and investigate if the chlorine generator is operating to its maximum capacity and for sufficient hours to meet the demand.

COMBINED CHLORINE - CHLORAMINES

A common cause for unusually high chlorine demand is the presence of chloramines in the pool water, detectable when a Total Chlorine test result is higher than a Free Chlorine test result by greater than 1.0ppm. The difference between these two test results is known as the "Combined Chlorine". More advanced test kits will include the Total Chlorine test, otherwise you will need to have your water tested professionally to check for this.

Chloramines are formed when free chlorine reacts with ammonia like compounds called 'amines', and this will build up over time. Chloramines are a poor disinfectant and also reduce the disinfecting power of the free chlorine in the water. Chloramines are irritating to the eyes and respiratory system, and are responsible for the "chlorine smell" most noticeable around heavily used indoor pools.

In commercial applications regular shock dosing is not always practical as this requires the pool to be closed for some time until the free chlorine levels are back to a safe range. For this reason commercial operators may instead use a technique called 'Continual Breakpoint Chlorination' to control chloramines in the water.

Note: When shock dosing, avoid the use of persulfate based products as this can adversely affect water test results. Pool Lab recommends to shock dose with liquid chlorine.

CONTINUAL BREAKPOINT CHLORINATION

The details of this topic are beyond the scope of this manual, however there is plenty of free literature and videos available about this online.

In very simple terms continual breakpoint chlorination is the practice of continually adding chlorine in a controlled manner, and while doing so continually monitoring the free chlorine residual. The point of this exercise is to find the point where the chlorine demand suddenly drops and the free chlorine residual starts increasing proportionally to the chlorine being added. This is an indication that the oxidant demand in the water has been met, and the remaining free chlorine is then available to sanitize the water. In heavy bather load commercial applications this should ideally be done every night after the pool is closed. Failure to do this you may lead to all the free chlorine residual being used up overnight which then requires heavy chlorine dosing in the morning before opening and leaving you in a situation where you are still battling demand from the previous day when the pool opens. If this pattern continues chloramines build up in the water, increasing the chlorine demand further and further each day. The pool environment will become increasingly unpleasant due to eye and respiratory irritation until the point where you may be forced to temporarily close the pool for superchlorination to rectify the problem.

Luckily for owners of Pool Lab systems with an ASP, and particularly when the filtration system runs 24 hours per day most of this procedure is somewhat inherent in the way the system operates. The only thing you need to do is check your water test results in the morning (MAIN MENU – HISTORY) to see if breakpoint has been achieved overnight, and this will be evidenced by one or more free chlorine test results that have overshoot the set free chlorine target.

If breakpoint is not achieved overnight, then you may simply need to increase the chlorine setpoint by a small amount (MAIN MENU – SETTINGS – CL TARGET).

Example: Breakpoint chlorination with a Pool Lab ASP.

Pool Lab systems with an ASP will always try to achieve your set free chlorine target (2.5ppm by default) with algorithms that monitor chlorine demand in the water. In high demand scenarios it will generally increase the chlorine dose after every test that is below target.

If the system runs overnight while no bathers are in the pool then chlorine will be delivered continually to achieve and maintain the chlorine setpoint. This may or may not achieve breakpoint chlorination, but it will be easy to see if this has occurred by checking the test result history.

The result of a chlorine test after breakpoint has been achieved will almost always be above the set target. This is due to the fact that chlorine demand in the water has suddenly dropped in between tests (ie. Breakpoint achieved). After this the chlorine dose will be reduced automatically to prevent overshooting the target further.

This is effectively automatic breakpoint chlorination.

If breakpoint is not achieved overnight, (ie. The free chlorine does not overshoot the target) this indicates that your free chlorine target may be too low for your bather load and water conditions. Try increase the CL setpoint by a small amount and check again the following day if breakpoint has occurred overnight.

WATER BALANCE

The balance of your pool water is no less critical because you have installed a salt chlorinator. All the parameters relating to water balance in Pool and Spa water must be constantly checked and adjusted.

We strongly recommend you seek advice from a pool professional regarding the balancing of water for your pool. A correctly balanced pool will protect it and the equipment from chemical damage and ensure bathers are swimming in clean clear healthy pool water.

pH

A high pH will reduce the effectiveness of chlorine, potentially cause scale on both the pool and the equipment, and irritate bathers. A low pH may cause the water to become corrosive, damaging the pool interior finish, equipment (heat exchangers especially) and also irritate bathers. Each pool finish and type has a specific range in which the pH should remain. Generally a pH of between 7.2 – 7.6 is suitable for most pool types, however those requiring a higher pH will also require a higher chlorine residual. (Consult with your pool shop)

TOTAL ALKALINITY

The total alkalinity is a measurement of all the alkalis in your pool water, (Carbonates, Bicarbonates and Hydroxides). When adjusted within the accepted levels, T.A. acts as a pH buffer, resisting changes to the pH level. The recommended T.A. level of your pool may vary from 80ppm – 120ppm depending on the pool finish, consult with a pool water professional for advice on the recommended range for your pool.

CALCIUM HARDNESS

The hardness of your pool water is very important in controlling scale and the corrosive effects of water. A low calcium level may cause pool water to become corrosive even if the pH is within its recommended range. A sign of this is brown stains on the pool finish and in adjoining Spas especially. This is metal staining, the source of which is usually the heater. A high calcium level may cause pool water to deposit scale, even if the pH is within its recommended range. The salt chlorinator cell may require very frequent cleaning and scale may deposit on pool finish and equipment. Generally a level of 100ppm – 200ppm is recommended. Consult with your pool builder or pool shop for specific advice on the correct level for your pool.

SALT LEVEL

The salt level in pool water is usually approximated either by measuring the conductivity of the water, or by using a test strip or reagent kit. Sometimes also referred to as T.D.S. Total Dissolved Solids, or salinity, which while technically slightly different are all close enough approximations for the range used in pool water. With a salt chlorinator, it is essential to have approximately the correct amount of salt in the water to achieve the conductivity required for the chlorine cell to work efficiently.

Pool Lab recommend using regular pool salt (Sodium Chloride).

CHLORINE STABILIZER – CYANURIC ACID

Use of Cyanuric Acid (Stabilizer) is generally not recommended in commercial applications as it reduces the effectiveness of the chlorine and increases the free chlorine residual required for effective sanitation when subjected to heavy bather loads.

The sun's ultraviolet light breaks down chlorine rapidly, so in domestic applications it is often beneficial to use a chlorine stabilizer in pools with exposure to the sun as this is usually the main source of chlorine demand. The benefits to this are that this extends chlorinator cell life, and often allows for a lower rated output chlorinator to be used on a given size pool where bather load is not too high.

However, in most commercial applications these benefits do not apply. With heavy bather loads the chlorine demand from pool users is far more significant than chlorine demand from sunlight. We would also never recommend to intentionally undersize the chlorinator in a commercial application.

High Calcium (Hard) water sources – the Langlier Saturation Index

Try Pool Lab's online LSI calculator at: <http://poollab.poolpower.com.au/langelier>

The Langlier Saturation Index (Si) is a relationship between the Calcium Hardness, Total Alkalinity, pH and water temperature. When the water is balanced correctly, the Si value should be somewhere between -0.2 and +0.2. A value lower than -0.2 indicates the water is corrosive, and a value higher than +0.2 indicates the water is scaling.

If you are in a situation where the water source for the pool contains a higher level of calcium than is recommended for your pool, then this index can be very useful. It will allow you to find a pH value that will not be corrosive or scale forming, and this pH value will generally be slightly lower than what would normally be recommended for your pool.

The following formula and reference chart can be used to find the current Si for your water. You will need to know the pH level, Total Alkalinity, Calcium Hardness and Temperature of your water.

Use the chart to determine the values for Ti, Ci, and Ai, and insert these values into the formula, along with the measured pH value to determine your Si value.

If you get an Si value higher than +0.2, then your water is scaling. In this case you should reduce the pH in your water by the value of Si to ensure your water is neither scaling or corrosive.

$$Si = pH + Ti + Ci + Ai - 12.1$$

Temperature Degrees C	Ti	Calcium Hardness	Ci	Total Alkalinity	Ai
12	0.3	75	1.5	75	1.9
16	0.4	100	1.6	100	2.0
19	0.5	125	1.7	125	2.1
24	0.6	150	1.8	150	2.2
29	0.7	200	1.9	200	2.3
34	0.8	250	2.0	250	2.4
39	0.9	300	2.1	300	2.5
		400	2.2	400	2.6
		600	2.4	600	2.8
		800	2.5	800	2.9

Example:

pH = 7.6, Temp = 24 (Ti = 0.6), Calcium = 400 (Ci = 2.2), Alkalinity = 125 (Ai = 2.1)

Si = 7.6 + 0.6 + 2.2 + 2.1 – 12.1,

Si = +0.4, so the water is scaling.

In this case we would take 0.4 away from the measured pH to find the ideal pH is 7.2. A pH value anywhere between 7.0 and 7.4 would be acceptable in this case.

WATER CIRCULATION

In commercial applications the filtration pumps should be sized so that the total volume of the swimming pool is turned over at least once every 6 hours, and the filtration period long enough to turn the pool volume over a minimum of 2 times per day.

With high bather loads it is best to run the pumps and chlorinators 24 hours per day where possible allowing the pool time to recover overnight so it is ready for use in the morning. This will significantly reduce the build up of chloramines in the water, thus reducing the need for shock dosing, and reducing the unpleasant chlorine smell on indoor pools.

Bathers should not be permitted to enter the pool when the filtration pumps are not running, and pumps should be ideally started at least an hour before the pool is open to bathers.

It is important to ensure you are maintaining at least the minimum daily turnover of water. If using a multi or variable speed pumps at low speed, you may need to consult the pump documentation to help determine the approximate flow rate you have.

If daily turnover is not maintained the chemical and sanitizer distribution in the water may not be uniform, and water test samples may not be representative of the entire pool volume. This can make chemical dosing inaccurate, and can increase the chance of forming black-spot algae on your pool surfaces and lead to generally poor water quality.

See examples below:

Traditional Fixed Speed Pool Pump

Pool Volume:	50,000 Litres
Pump Rated Flow:	210 LPM (Litres per minute)
Turnover Rate:	approx. 4 hours. (238 minutes)
Time to turn over 1.5 x pool volume:	approx. 6 hours (357 minutes)
Time to turn over 2.0 x pool volume:	approx. 8 hours (476 minutes)

This example illustrates that when you halve the flow rate, you effectively need to double the filtration time.

When performing manual pH and chlorine tests for comparison with ASP results, always obtain the sample as close as possible to the filtration system inlet – usually the skimmer box. This place will be most representative of the readings acquired by the Pool Lab ASP. Also ensure the displayed results are up-to-date by initiating a water test via the ASP TOOLS menu.

INSTALLATION

PLUMBING

Cell Installation

The Cell housings must be installed vertically with the inlet and discharge plumbing positioned such that the water enters and exits the cell chamber at the lowest point of the vertical cell. Pool Lab cell housings are directional, so take note of the direction of flow label on the cell housing and ensure the cells are installed in the correct direction.

50mm pipe must be plumbed directly onto both ends of the cell with the water flowing in the direction as indicated by the arrow on the cell housing.

50-40mm reducing bushes will be required for 40mm plumbing.

Do not use barrel unions directly on both sides of the horizontal plumbing that connect to the cell housing. Unions may loosen and cause the cell to rotate from a vertical upwards position which will disable the physical ability for the cell to contain a hydrogen gas build up.

Barrel unions can be used, but must be arranged so that the cell cannot rotate if they are loosened. For example, if at least one of the unions is on a vertical or perpendicular pipe leading to the cell.

Positioning the Cells

The cells must be installed on the pool return line, DOWN STREAM of all other equipment such as the filter, heaters and solar heaters. This is very important in preventing accumulation of Hydrogen gas as well as corrosion of equipment such as a heat exchange. Where the cells are installed below pool water level, ensure isolating valves are installed somewhere either side of the cell, so it can be inspected or removed.

Multiple Cell Installations

Pool Lab Hybrid systems can use anywhere between 1 and 5 chlorine cells, depending on the output required. When multiple cells are installed care must be taken to ensure all cells have sufficient flow, being at least 100 Litres per minute for each cell. This can be achieved by simply installing the cells in series with each other, or where higher flow is required by splitting into parallel branches.

On systems with multiple separate filtration systems, cells can also be divided between the filtration systems.

Plumbing Examples

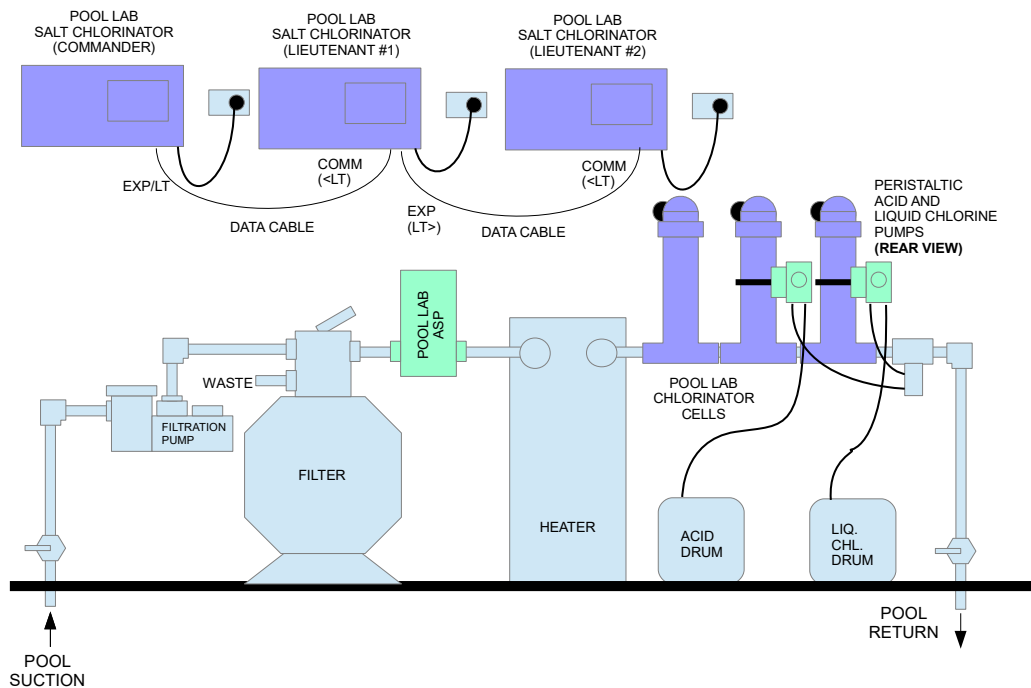

ASP (Auto Sampling Photometer)

The Pool Lab ASP must be positioned AFTER the filter, and BEFORE any heating equipment, solar equipment, chlorine cells, or ozone injection points. The ASP flow switch is bi-directional so water can flow in either direction through this device. Ensure there is enough space above the ASP so that the reagent cover can be easily removed.

Acid and Liquid Chlorine Injection

The dual port injector must be installed in the return line AFTER the chlorinator cells. This fitting should be plumbed with the dual port housing pointing downwards or horizontal. The inner port is for liquid chlorine, and the outer port for acid.

WARNING: The injection ports on the cell housings can be used if necessary, but the acid injector must be placed on the LAST cell in the series. Injected acid should not be allowed to pass through any chlorinator cells.

Multiple Cell Plumbing Configurations

The chlorinator cells must be plumbed into the filtration system return line.

The most appropriate configuration of the cells for your system will depend on:

- A. The number of cells required (Hybrid 45 = 1, Hybrid 225 = 5)
- B. The pump size, filtration line pipe size, and flow rate required.
- C. Single or multiple independent filtration systems.

If there are multiple independent filtration systems on the pool, cells can be divided between the filtration systems.

Where multiple cells are to be plumbed in parallel it is important that all parallel branches are designed for approximately equal flow, and that the flow rate is sufficient to deliver a minimum of 100 LPM to each branch. Differences in pipe length, cell height from the ground/floor, number and type of fittings, etc. in each branch can have a significant effect on the balance of flow.

See the examples below to decide which approach is the most appropriate for your system.

Simple In-line Configuration

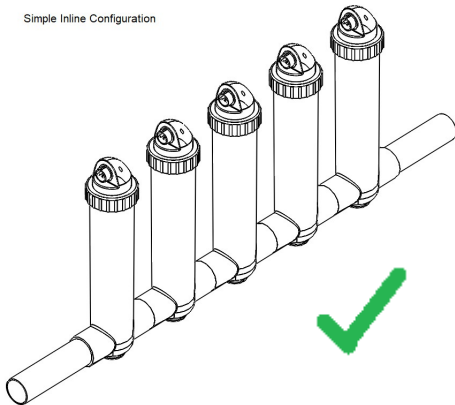

Simple In-line Cell Configuration

The simplest method is to plumb the cells in series, ensuring all cells are guaranteed equal flow at the cost of some flow restriction. This method is generally suitable for smaller pools and spas with a single filtration system and a pump under 2 HP. (minimum flow rate 100 LPM)

Balanced Parallel Configurations

Balanced Twin Cell Configuration
50mm plumbing

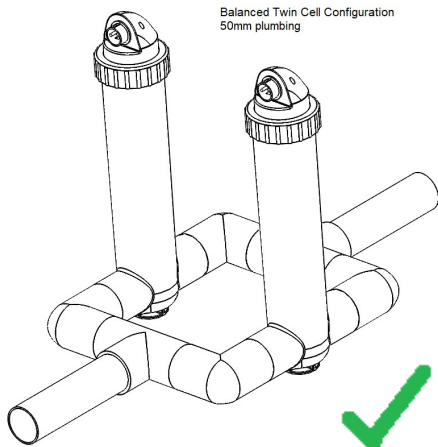

For higher flow rates with 2 or 4 cells, the cells can be split into two parallel banks. Care must be taken to ensure both banks receive similar flow. In the examples shown this is achieved with a symmetrical layout. This method is suitable for mid-sized systems and pumps 2 HP or larger. (minimum flow rate 200 LPM)

Balanced Quad Cell
Series / Parallel Configuration
50mm plumbing

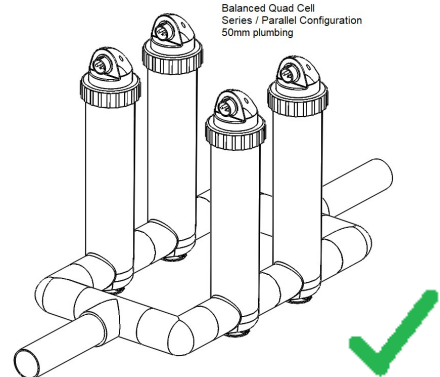

High Flow Parallel Cells with balancing loop

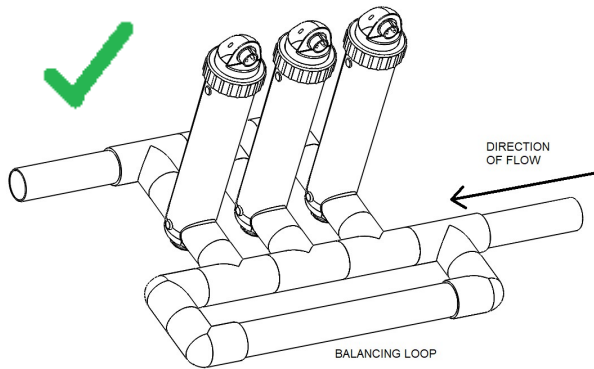

This configuration is the least restrictive in terms of flow, however it does require a larger pump.

This layout is recommended for large high flow systems including those with 65mm plumbing and pumps over 3HP. To ensure sufficient flow through all the cells, as a general guide we recommend a pump of at least 1HP for each parallel cell. (ie. 5 HP pump for 5 cells)

It is strongly recommend to use a balancing loop as it will significantly help to equalize the flow through the cells and reduce the potential for cell flow balance issues. Any water that bypasses the cells due to inertia will then be recycled through the balancing loop back to the cell inlets. (minimum flow rate 100 LPM per cell)

Cell Layouts to Avoid

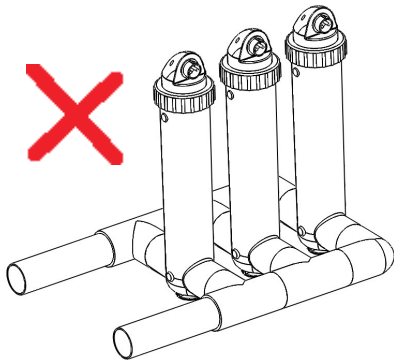

Unbalanced parallel cells

In this example the last cell (with 90 degree fittings) will receive significantly more flow than the other two cells. The inertia of fast moving incoming water will tend to carry more water straight through the T-fittings than to the intermediate cells. The last cell is also the path of least resistance for the water due to the 90 degree fittings being more efficient than water flowing at 90 degrees through a T-fitting.

False symmetry

This example will suffer similar problems to the previous example as inertia will carry more water to the cell farthest from the inlet. The centre cell in this design will receive the lowest flow as this path has more resistance.

Adding a balancing loop to the inlet side of either of these designs will significantly improve the balance of flow through the cells.

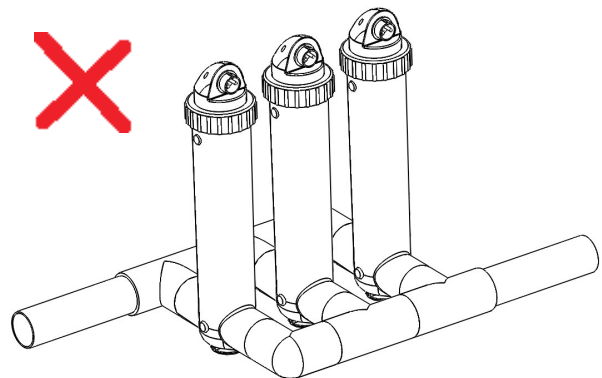

Air Blower Installation – If an air blower is installed and connected directly to venturi spa jets, then a vented loop must be installed. This allows any potential build up of hydrogen gas to escape from the blower line before it comes in contact with the blower motor.

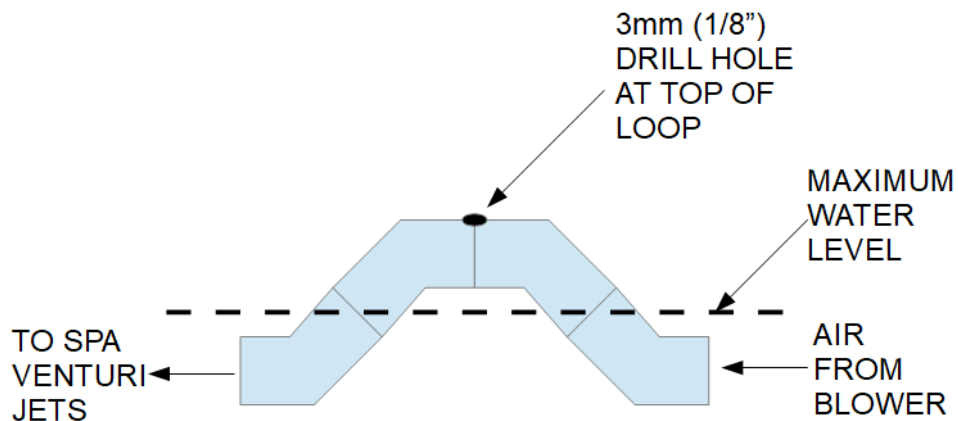

NOTE: The top of the loop must be above the maximum water level in the spa.

Chemical Injection

The dual port liquid chlorine and acid injection housing should be plumbed into the filtration water circuit AFTER the chlorinator cells.

The Tee fitting should be installed with the threaded port facing downwards if possible, otherwise horizontal is also acceptable to prevent air being trapped in the injector housing.

The liquid chlorine injector should be installed on the inner port.

The acid injector on the outer port as shown below.



1. Ensure the o-rings are in place before threading the injector fittings into the housing.
2. Slide the locknuts over the acid and liquid chlorine tubes.
3. Push tubing onto the injector fitting barbs.
4. Carefully tighten locknuts (hand tight only) whilst holding the injector fitting to prevent overtightening the injector into the dual port housing.

POWER SUPPLY AND CONTROLLER

The Pool Lab power supply and controller enclosures are supplied with a mounting bracket, three screws and three masonry plugs. To comply, the unit must be mounted vertically with the outlet socket facing downwards on a solid wall or post that covers an area no less than the rear area of the back of the power pack. Always mount the power pack as per local electrical codes and within 3m of the cell and 2m from the pool pump to ensure power leads will reach. Air flow around the power supply must not be restricted or close to any heat source such as a gas heater exhaust.

The unit is suitable for outdoor installation and has an IP23 rating. The unit must be mounted outside of the pool zones as defined by AS/NZS 3000. As a general rule for swimming pools, Pool Lab units must be mounted at least 3.5m away from the inside edge of the pool to be clear of the pool zones, and at least 45cm above the ground to protect from water being splashed up from the ground.

The Pool Lab chlorinator should be mounted so that the equipment such as the filtration pump can be easily connected.

Masonry plugs and screws are provided with the mounting bracket, and the screws provided are also suitable for mounting directly to timber.

Secure the mounting bracket in place with the slotted edge to the top, and ensure the bracket is level and firmly secured before mounting the Pool Lab unit onto it.

The bracket at the back of the unit hooks over the slots on the top edge of the mounting bracket. Optionally you can secure the unit to the bracket with the M3x16mm screws provided.

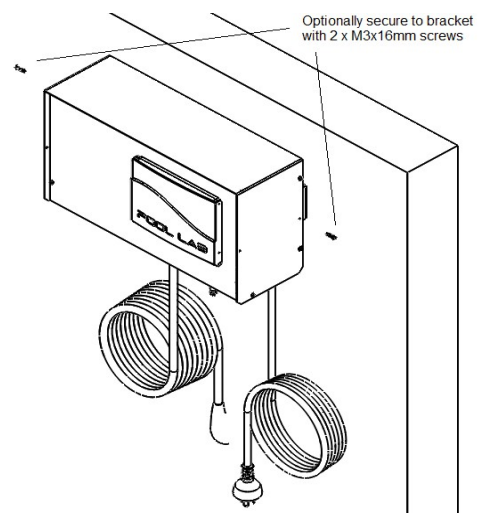
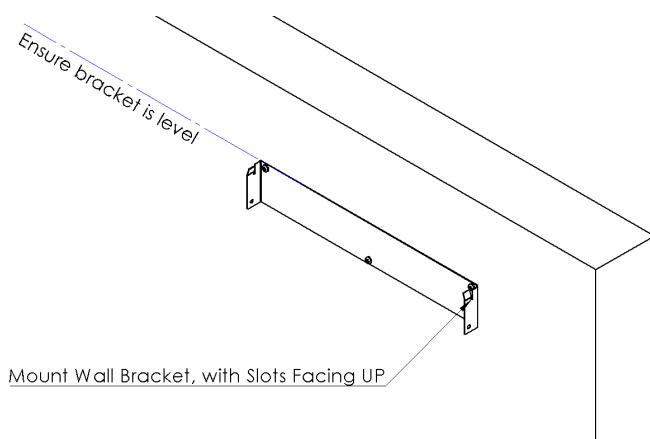

WIRING DATA CABLES AND ACCESSORIES

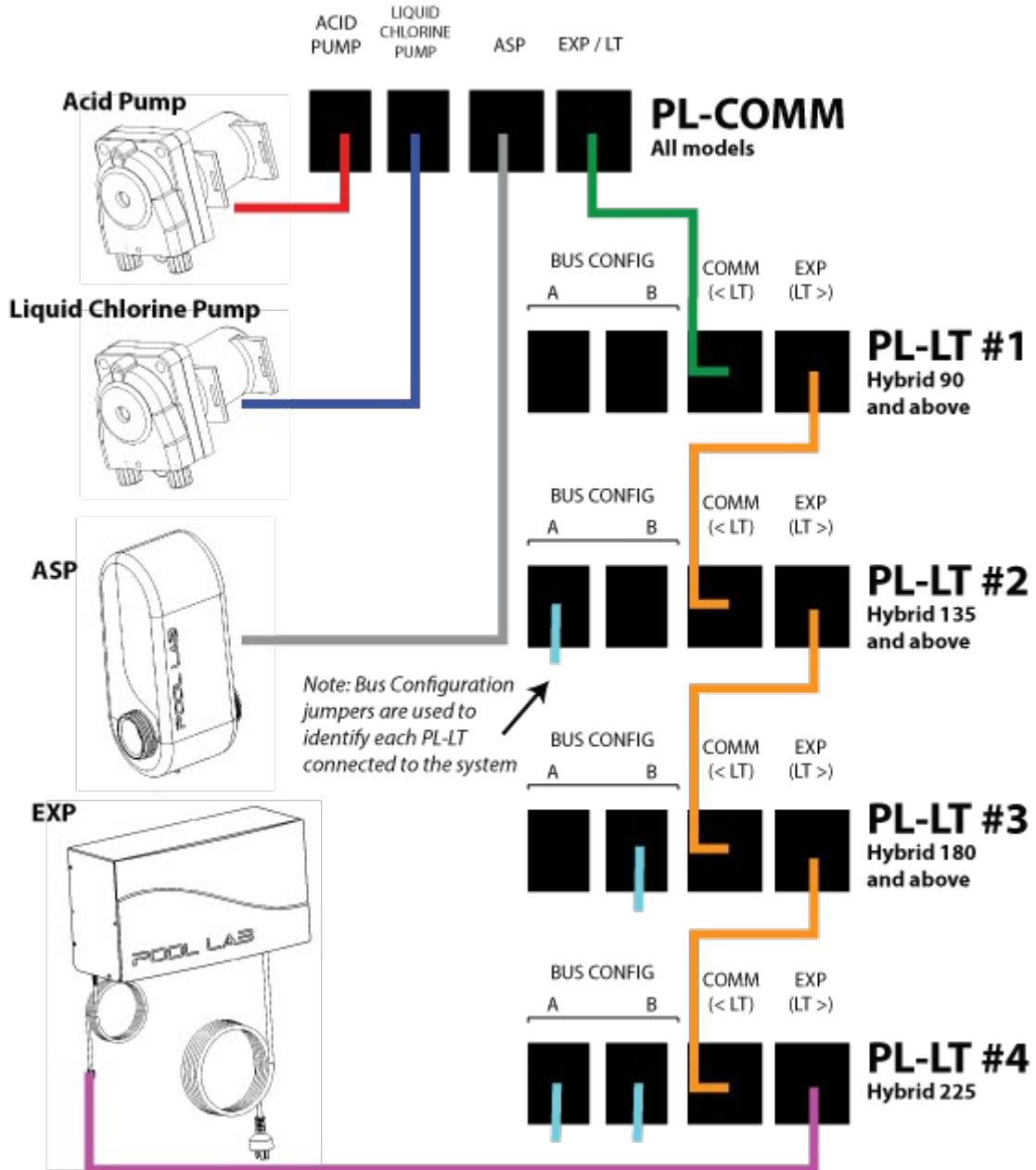

Pool Lab EXP connects to the EXP port of the last PL-LT (or PL-COMM for Hybrid 45 models)

THIRD PARTY EQUIPMENT CONTROLLERS

This section applies to any setup where the filtration pump(s) are not connected to the filter pump outlet sockets on the PL-COMM and PL-LT units. This also applies to externally controlled pumps that are normally set to run 24 hours per day.

When a Pool Lab Hybrid is installed on a system with externally controlled filtration pump(s), please setup as described below.

- Filtration pump(s) connected to the third party controller.
- Pool Lab PL-COMM connected to continuous power.
- Pool Lab PL-LT units can either all be connected to continuous power, or to reduce the number of power outlets required it is also acceptable to daisy chain the units together using the pump socket of the previous units.
 - ie. PL-LT #1 power cord connected to the pump socket of the PL-COMM,
 - PL-LT #2 power cord connected to the pump socket of PL-LT #1,
 - PL-LT #3 power cord connected to the pump socket of PL-LT #2,
 - PL-LT #4 power cord connected to the pump socket of PL-LT #3.
- Pool Lab PL-COMM left in manual ON mode.
- Ensure filtration timer #1 is set to the approximate same run time as the third party controller. This is used to calculate water test frequency. For pump(s) running 24 hours per day, set timer #1 to 0:00 – 23:59
- Disable timer #2 (disabled by default) – set to 0:00 – 0:00 to disable.
- Ensure “Pump Protection Monitor” is disabled (ie. set to ZERO).

Note: Some built in features that affect the filtration pump outlet will not function in this configuration, however these features are generally not critical. These include the PUMP PROTECTION MONITOR, AUTOMATIC PLUMBING FLUSH, and where an EXP module is connected the HEATER COOL DOWN TIMER and SOLAR PUMP OVERRIDE

WARNING - ISOLATE AND DISCONNECT SUPPLY POWER BEFORE SERVICING CHLORINATOR OR PUMP.

CAUTION - FOR CONTINUED PROTECTION AGAINST POSSIBLE ELECTRIC SHOCK USE ONLY IDENTICAL REPLACEMENT PARTS WHEN SERVICING.

POWER RATINGS

PL COMM

Input: 220-240VAC, 50-60Hz, 10A MAX TOTAL LOAD
Power Supply Input: 220-240VAC, 50-60Hz, 1.6A MAX
Output (Filter Pump): 220-240VAC, 50-60Hz, 8.4A MAX
Output (Cell): 24VDC, 13.4A MAX, 7.5A IDEAL
Output (Acid Pump): 24VDC, 1.0A MAX
Output (Liquid Chlorine Pump): 24VDC, 1.0A MAX
Output (ASP): 24VDC, 1.0A MAX
Output (Multispeed Pump):
 3 x Dry Contact, 24V AC/DC, 1.0A MAX TOTAL
Grounded IP23
AS/NZS3136:2001+A1+A2 Approval No. NSW27913

PL LT

Input: 220-240VAC, 50-60Hz, 10A MAX TOTAL LOAD
Power Supply Input: 220-240VAC, 50-60Hz, 1.6A MAX
Output (Filter Pump): 220-240VAC, 50-60Hz, 8.4A MAX
Output (Cell): 24VDC, 13.4A MAX, 7.5A IDEAL
Grounded IP23
AS/NZS3136:2001+A1+A2 Approval No. NSW27913

Power Consumption

(typical average, ideal salinity @ 25 degrees celcius):

PL COMM & PL LT models @ 100% chlorine output:	195 Watts
PL COMM & PL LT models @ standby:	6.4 Watts

Pool Lab Add-on modules and accessories

Detailed installation instructions are included with the Pool Lab add-on modules and accessories, please refer to these documents for more detailed information.

ASP

The power/data cord from the ASP connects to the Pool Lab Salt Chlorinator into the socket labelled “ASP” and the peristaltic acid pump connects to the Pool Lab Salt Chlorinator into the socket labelled “ACID PUMP”.

IMPORTANT NOTE: When installed on a pool and spa combination system, a SPA FLOW SWITCH is required (sold separately, see below).

Please ensure the following system configuration items are set and correct before use:

- POOL VOLUME (default is 50,000 L)
- SPA VOLUME (default is 2,000 L – this can be safely ignored if there is no spa, and no spa flow switch installed)

EXP

For all models except PL Hybrid (PL COMM and PL LT), the data cable from the EXP connects to the Pool Lab Salt Chlorinator into the socket labeled “EXP”.

(For PL Hybrid systems see below)

The EXP module is fitted with a power lead which should be connected to constant power.

Pool or other equipment to be controlled by the EXP module should be plugged into the outlet sockets at the bottom of the unit.

The water temperature sensor should be installed into the pipe on the filtration water circuit, preferably before the filtration pump, and connected to the terminals labeled “FILTER CIRCUIT TEMP SENSOR” in any polarity.

If controlling a solar system, the solar sensors (sold separately) will need to be installed with the solar inlet sensor into the pipe on the inlet side of the solar array, and the roof sensor mounted into a small piece of solar matting on the roof near to the solar sensor array.

SPA FLOW SWITCH (Domestic Plus and MAX models only)

PL-COMM and PL-LT models are not compatible with pool and spa combinations that operate from a single filtration system, and therefore do not have a connection port for a spa flow switch. The only exception to this would be if the spa is continually overflowing into the pool and is never isolated (ie. Filtering the spa water only)

Due to the fact that the chlorine and acid demand requirements for pools and spas are very different, in commercial applications we recommend to treat pool and spa combinations as two separate bodies of water with independent filtration systems and independent Pool Lab Hybrid systems.

SALT

- ONLY USE APPROVED POOL GRADE SALT THAT IS SPECIFICALLY LABELLED FOR SWIMMING POOL AND SPA USE
- SALT MUST BE GREATER THAN 99% PURE
- DO NOT USE ROCK SALT, SALT WITH YELLOW PRUSSIAN OF SODA, SALT WITH ANTI-CAKING ADDITIVES OR IODIZED SALT.
- ADD SALT TO POOL WATER AS FAR AWAY FROM THE FILTRATION SYSTEM SUCTION POINTS AS POSSIBLE.
- CLOSE MAIN DRAIN VALVE WHERE APPLICABLE BEFORE ADDING SALT FOR AT LEAST 24 HOURS
- REMOVE ANY SUCTION DRIVEN POOL CLEANERS FROM THE WATER FOR AT LEAST 24 HOURS.

INITIAL SALT DOSING

Do not assume a pool full of water whether it is new or old has a zero salinity. A substantial amount of salt may be present in the water if the pool was previously treated with liquid chlorine or if the pool is filled by a water source high in salt. Depending on the geographical area, the tap water may have a high salinity level.

It is important to test the water first before calculating the initial salt dosage or you may over-salt the pool water.

Use the SALT ADDITION TABLE on the next page to quickly calculate the amount of salt required to bring your water to the ideal salinity level of 3000ppm. You will need to know your current salinity level in parts per million (ppm) and your pool water volume in Litres.

Please note: Although the salt chlorinator diagnostics will advise when to add salt and when not to add salt, you must always perform a salt test using a test kit or salinity meter to confirm the findings before making a salt addition.

SALT ADDITION TABLES

The Ideal Salinity Level for Pool Lab Salt Chlorinator models:
 PL25, PL35 and PL45 (including Plus and MAX models) - **3000ppm**.
 PL ECO - **5600ppm**

Use the table below to calculate the amount of salt required to bring your water to the ideal salinity level.

Current Salt Level (ppm)	Pool Volume (Litres)									
	10000 L	20000 L	30000 L	40000 L	50000 L	60000 L	70000 L	80000 L	90000 L	100000 L
0	30 kg	60 kg	90 kg	120 kg	150 kg	180 kg	210 kg	240 kg	270 kg	300 kg
250	28 kg	55 kg	83 kg	110 kg	138 kg	165 kg	193 kg	220 kg	248 kg	275 kg
500	25 kg	50 kg	75 kg	100 kg	125 kg	150 kg	175 kg	200 kg	225 kg	250 kg
750	23 kg	45 kg	68 kg	90 kg	113 kg	135 kg	158 kg	180 kg	203 kg	225 kg
1000	20 kg	40 kg	60 kg	80 kg	100 kg	120 kg	140 kg	160 kg	180 kg	200 kg
1250	18 kg	35 kg	53 kg	70 kg	88 kg	105 kg	123 kg	140 kg	158 kg	175 kg
1500	15 kg	30 kg	45 kg	60 kg	75 kg	90 kg	105 kg	120 kg	135 kg	150 kg
1750	13 kg	25 kg	38 kg	50 kg	63 kg	75 kg	88 kg	100 kg	113 kg	125 kg
2000	10 kg	20 kg	30 kg	40 kg	50 kg	60 kg	70 kg	80 kg	90 kg	100 kg
2250	8 kg	15 kg	23 kg	30 kg	38 kg	45 kg	53 kg	60 kg	68 kg	75 kg
2500	5 kg	10 kg	15 kg	20 kg	25 kg	30 kg	35 kg	40 kg	45 kg	50 kg
2750	3 kg	5 kg	8 kg	10 kg	13 kg	15 kg	18 kg	20 kg	23 kg	25 kg
3000	IDEAL	IDEAL	IDEAL	IDEAL	IDEAL	IDEAL	IDEAL	IDEAL	IDEAL	IDEAL
3250	OK	OK	OK	OK	OK	OK	OK	OK	OK	OK
3500	HIGH	HIGH	HIGH	HIGH	HIGH	HIGH	HIGH	HIGH	HIGH	HIGH
3750+	DILUTE	DILUTE	DILUTE	DILUTE	DILUTE	DILUTE	DILUTE	DILUTE	DILUTE	DILUTE

Operation at near to the ideal salinity will maximise cell life, self-cleaning efficiency and chlorine output.

In cases where water temperature is continually maintained above 35°C the ideal salinity is effectively reduced by approximately 500ppm.

For all models except PL ECO the absolute maximum salinity level for reliable chlorine production is approximately 5000ppm @ 25°C, but continued operation at this level is not recommended and water should be diluted* as soon as possible to reduce the salinity.

The absolute maximum salinity for PL ECO models is approximately 7600ppm @ 25°C

(Note: for software CLR-P24-258 and lower, the absolute maximum salinity is 4500ppm)

Salinity levels higher than the absolute maximum, or water temperatures higher than 25°C at near to absolute maximum salinity may cause the chlorinator to stop producing chlorine in order to protect the power supply and electrode from damage.

* Pumping out a percentage of the water and refilling with fresh water is the fastest way to reduce salinity. In cases where water cannot be pumped out below the skimmer level this may need to be repeated several times if salinity needs to be reduced significantly.

TROUBLESHOOTING

SYMPTOM / DISPLAY MESSAGE	POSSIBLE CAUSES	POSSIBLE SOLUTIONS
No Display	No Power	Check for power at socket
	External Timer	An external timer (if fitted) may not be providing power
	Internal Fuse	Return unit for servicing
Unit resetting, or power cycling	An excessively high salt level may cause the power supply to shut down to protect from overload.	Check salt level in water. If salt level is too high you may need to pump some water to waste and then top up pool with fresh water. Consult your local swimming pool professionals for advice on this procedure.
	Short circuit in cell	Disconnect cell lead from cell. If the problem does not occur with the lead disconnected then this may indicate a short circuit in the cell. Check cell for damage such as displaced or touching plates. Also check for metallic debris that may be causing a short circuit.
	Short circuit in cell lead, faulty power supply, or faulty PCB.	If the problem persists with the cell lead disconnected then the unit will need to be returned for servicing.
Display Message: "PUMP PROTECTION ACTIVE"	Low flow was detected for longer than the time specified in the settings	Restart pump by pressing the MODE button, and select either AUTO or ON mode as required. See LOW FLOW message below for further instructions.
	This can occur during backwashing, rinse or while pumping to waste if the procedure takes longer than the time specified in the settings.	The cell cannot detect flow whilst water is not returning to pool. Extend the PUMP PROTECTION TIME to suit your needs, or disable it by setting to ZERO. If pumping large amounts of water to waste it is recommended to disconnect the chlorinator and connect the pump directly to mains power for this procedure.
	Cell not connected	Pump protection will activate if the cell lead is not connected. Disable pump protection to override this (if intentional), or reconnect the cell lead.
Display Message: "LOW FLOW (CELL)"	Cell does not have enough water flow to evacuate gas. (Evident by an air pocket at the top of the cell)	<ul style="list-style-type: none"> Check skimmer baskets for debris Check pump basket for debris Backwash Filter (sand filter) Clean Filter Cartridges (cartridge filter) Check valve positions Check for debris or obstruction in cell Check water level
	Leak on suction side of pump Plumbing leaks on the suction side of the pump can cause air to be pushed through the filtration system, which both reduces flow significantly and creates air pockets that can become trapped in the cell.	

SYMPTOM / DISPLAY MESSAGE	POSSIBLE CAUSES	POSSIBLE SOLUTIONS
Display Message: "CHECK SALT"	Salt level too low	Check salt level and add salt if required.
	Temperature too low	When water temperature is below 25°C the cells may not be able to produce at 100%. This will generally not be an issue if bather load is low, however if cold water conditions are expected for a significant amount of time then increasing the salt level to 3500ppm may solve the problem.
	Calcified or blocked cell. Visually inspect cell for a build up of white calcium or other deposits / debris between plates.	Refer to CELL MAINTENANCE section.
Display Message: "CHECK SALT (OFF)"	Very low salt level, unit will not produce chlorine to protect cell from damage	Check salt level and add salt if required.
	If salt level and water temperature are normal and cell is clean, this may indicate a worn cell.	Have cell checked and replace if necessary
Display Message: "HIGH SALT"	Salt level too high	This is a warning only. Chlorinator will be operating normally unless the "HIGH SALT (OFF)" message is displayed (see below). Do not add any more salt. Top up pool with fresh water if possible.
	High Water temperature	A combination of a high salt level and high water temperature can trigger this warning. No action is required unless the "HIGH SALT (OFF)" message is displayed (see below).
Display Message: "HIGH SALT (OFF)"	Very high salt level detected, possibly combined with high water temperature. Cell has shut down to protect from damage.	Check salt level in water. If salt level is too high you may need to pump some water to waste and then top up pool with fresh water. Consult your local swimming pool professionals for advice on this procedure.

SYMPTOM / DISPLAY MESSAGE	POSSIBLE CAUSES	POSSIBLE SOLUTIONS
Display Message: "HIGH SALT/RESET" System resets after 30 seconds.	Software detected a drop in the power supply voltage. Chlorinator cell is turned off and a system reset is scheduled after a 30 second delay. <i>This message may appear briefly when mains power to the unit is disconnected, this is normal behavior.</i>	This is usually caused by excessive current to the chlorinator cell exceeding the power supply limit, or can also occur if mains power is briefly interrupted. Otherwise this may indicate a faulty power supply. Check salt level in water, and check cell for debris or damage such as displaced or touching plates. If salt level is ok and problem persists, return unit for servicing.
	If this message appears immediately after the addition of salt to the water it is likely that some water with a very high salt concentration has been drawn into the the filtration system.	You may need to run the filter pump for some time without the chlorinator connected so that the newly added salt has time to dissolve and disperse into the water. When adding salt to the water try to ensure it is added as far away from the filtration system suction points as possible. Close main drain suction valve where applicable and remove any suction driven pool cleaners from the water. Never add salt directly to the skimmer
No residual free chlorine in water	Chlorinator not running sufficient hours per day	Extend the running time. A minimum 12 hours per day is recommended in low demand commercial applications, and 24 hours per day for medium to high demand.
	High chlorine demand due to high total chlorine.	Shock dose the pool with liquid chlorine. Consult your local swimming pool professionals for advice on this procedure.

Hint: Holding the BACK button for 3 seconds from the HOME view will show detailed information on the output to the chlorine cell including VOLTAGE, AMPS, and POLARITY.

For all models, cell voltage should be close to 24.0V (+/- 1.0 V)

Cell current is directly proportional to conductivity in the water. The major contributing factors to conductivity in pool and spa water is the salt level and the water temperature. Higher salt levels will increase conductivity and therefore increase cell current. Colder water will reduce the cell current, and warmer water will increase it.

For PL-COM and PL-LT models, cell amps should be between 5.7A – 12A.

The minimum current required for achieving 100% chlorine output is 7.5 A.

CHECK SALT warning is triggered below 5.7 Amps, HIGH SALT WARNING is triggered above 12 Amps.

Ideally the cell current should be maintained between 7.5 – 9.5 Amps under normal operating conditions. This allows some tolerance so fluctuations in water temperature do not trigger the HIGH SALT and CHECK SALT (LOW) warnings.

During normal operation the cell will cycle ON and OFF over a 3 minute duty cycle to maintain the correct chlorine output (as measured in grams per hour).

Cell amps vary in relation to the salt level, water temperature and condition of the cell.

WARRANTY INFORMATION

COMMERCIAL APPLICATIONS

Product Warranty – Control Box and Cell
1 Year Warranty – NEW for OLD exchange

Labour Warranty – Control Box and Cell
1 Year Warranty – in-field labour within 30km of an authorised service agent.
1 Year Warranty – workshop repair labour

CONDITIONS

- **In-field labour charges will apply to units installed for a period exceeding 12 months.**
- In-field labour charges may apply within the 12 month period if location is more than 30 km from an authorised service agent.
- Freight charges are the responsibility of the home owner.
- Under no circumstances shall the manufacturer be liable for incidental or consequential damages, inconvenience or expenses in connection with the removal, installation or replacement of equipment.
- Under no circumstances shall the manufacturer be liable for damage caused to persons or property as a result of use of this equipment.
- Charges will apply during the warranty period if installation or method of operation is not in accordance with **our** instructions.
- Warranty extending beyond 1 year is not transferable.
- **Purchase receipt** must be produced to claim warranty.
- The use of bore water may void warranty where not managed correctly***, and any associated discolouration or staining is not covered by warranty.

THE FOLLOWING INVALIDATES WARRANTY

- Incorrect installations
- Incorrect use
- Misuse
- Water in excess of 40 degrees Celcius, or lower than 0 degrees Celcius.
- Water pressure exceeding 250 kpa
- Where used for a purpose other than described in this manual
- Use of non-genuine components
- Use of chemicals or optional equipment not authorised for use by Pool Lab
- Where immediate action has not been taken to rectify a problem

**** Always use the Langelier Index to determine the ideal pH for bore water. Damage caused by the formation of scale is not covered by warranty.*

NOTES